

REVISIONS

NO.	날짜	내용	작성자	확인	승인
1	2021-03-20	FOR APPROVAL			
2	2021-03-20	FOR REVISION			
3	2021-03-20	FOR FINAL			

하이웨어 300 유틸리티 사양

	HSM		WFI	
	공급위치	용량	공급위치	용량
POWER	메인 판넬 220vx4Px	40 Kw	메인 판넬	2 Kw
AIR	메인 판넬	25Ax6bar	WFI 판넬	15Ax6bar
STEAM		N/A	정제수가열용	40Ax3bar
DRAIN(S)		N/A	영구물가드레인	32A
C, W		N/A	예비 세척	32A
DRAIN(G)	WIP드레인	50A	잔량드레인	32A
경제수		N/A	WIP 공급	1.5Sx3bar

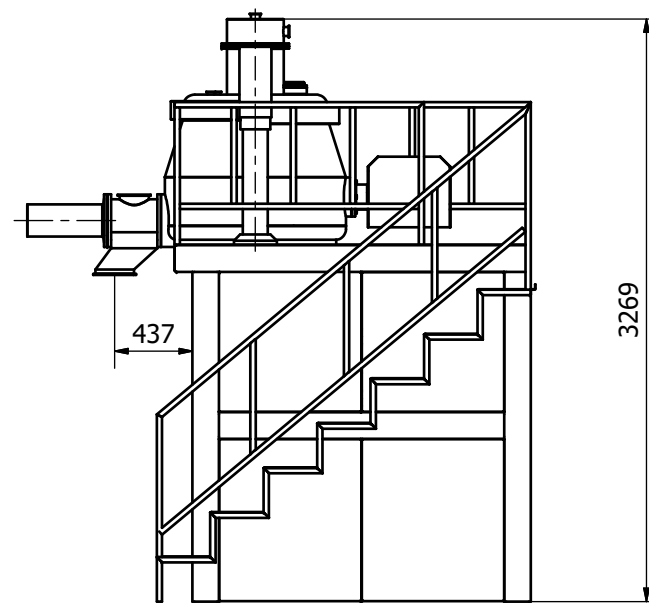
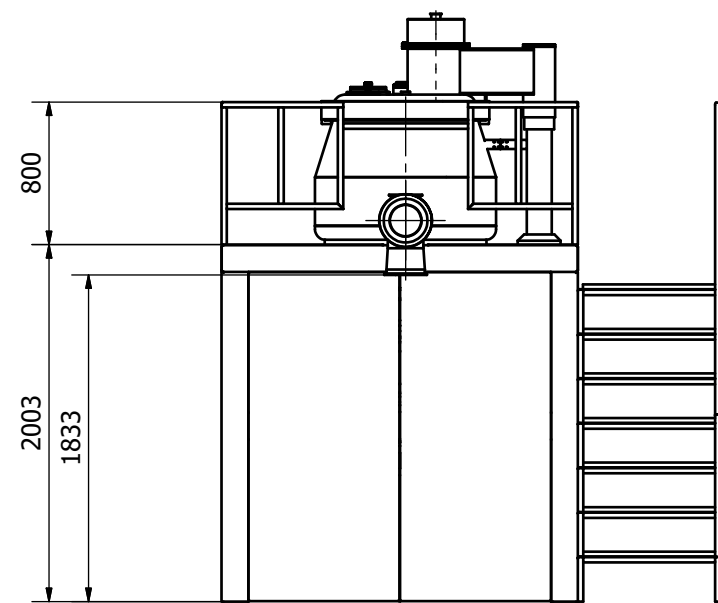
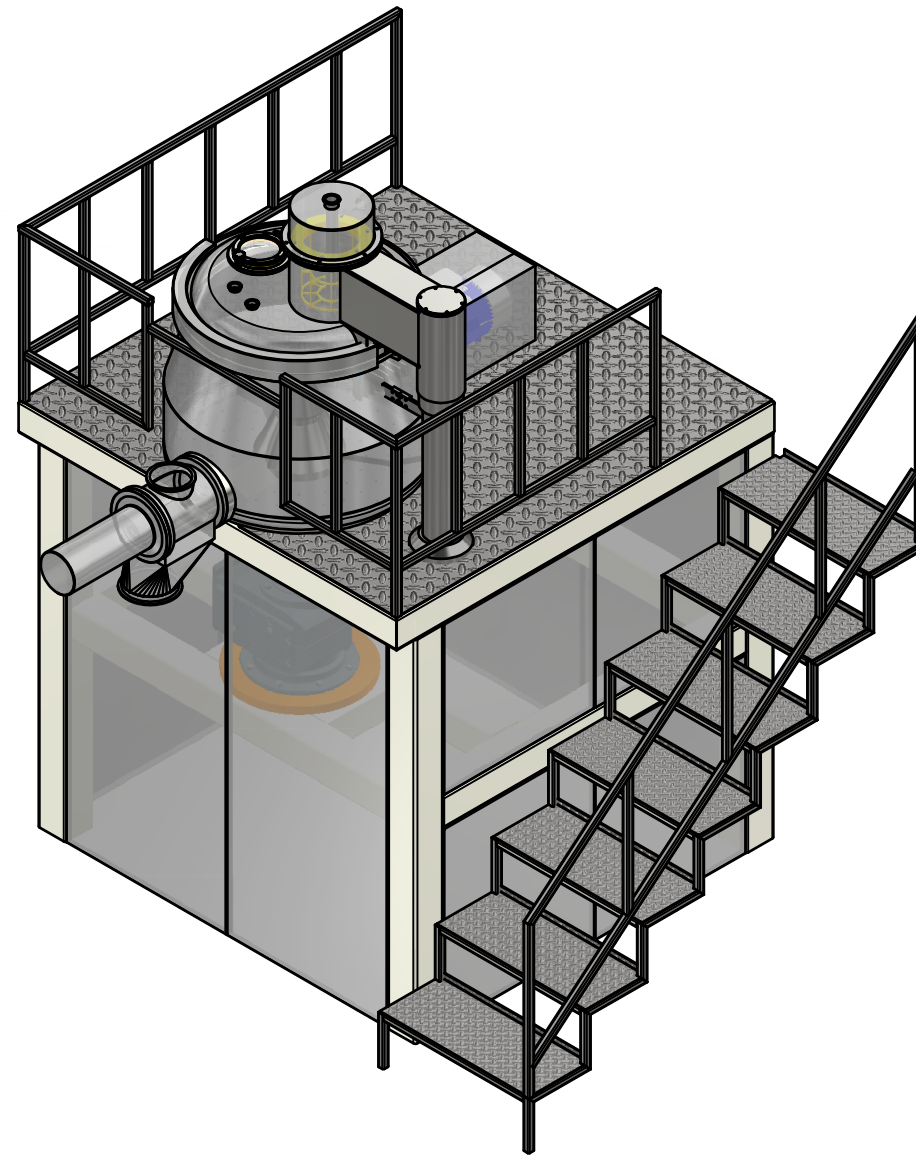
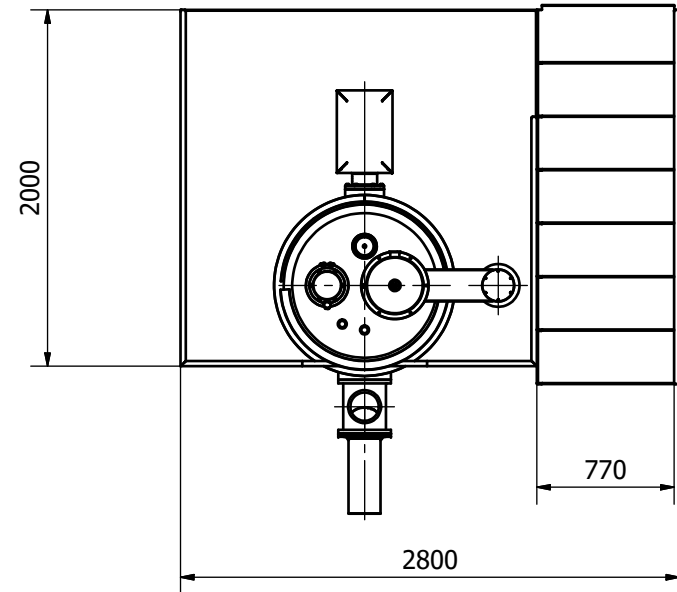

NOTES

- ALL DIMENSIONS ARE IN "MM" UNLESS OTHERWISE NOTED.
- ALL WELD INSIDE SURFACE NOZZLES TO BE FULLY FLUSH
- NOZZLE PROJECTIONS ARE FROM CENTERLINE OF VESSEL OR NEAREST TANGENT LINE TO GASKET FACE OF FLANGE.
- SURFACE FINISH

INTERNAL	0.5	Ra 이하
EXTERNAL	0.6	Ra 이하
- GASKET MATERIAL : TEFLON + SILICON
- MAT'L : ALL A240-316L(BEARING 304)

Order :	Scale : 1 : 30	Weight : 해당 없음
Dwg no : HSM 200Kg		
Revision	Date	Name
Project :		
		
경기도 안산시 단원구 선단로 19번길 174 (북내동) 1at.co.kr 031) 493-6864		